

COOLED RACK LIFTER

ES Doble Cremallera Refrigerada DE Gekühltes Zweifach Zahnstangen System
 IT Doppia Cremagliera con Refrigerazione PT Duplo Rack Refrigerado FR Double Rack Réfrigéré

● Cad Insertion Point

KR

UNDERCUTS



Patented

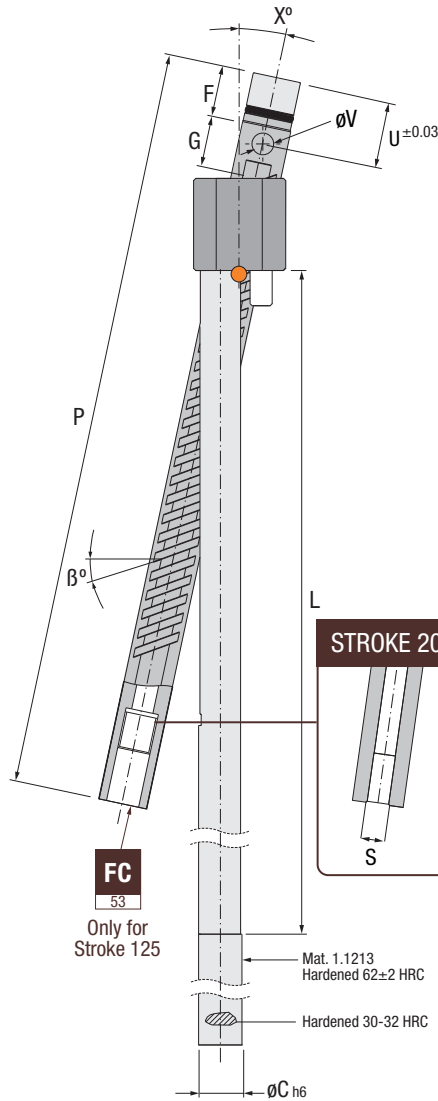

FC
53
Only for Stroke 125

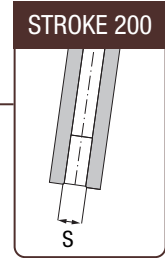

STROKE 200

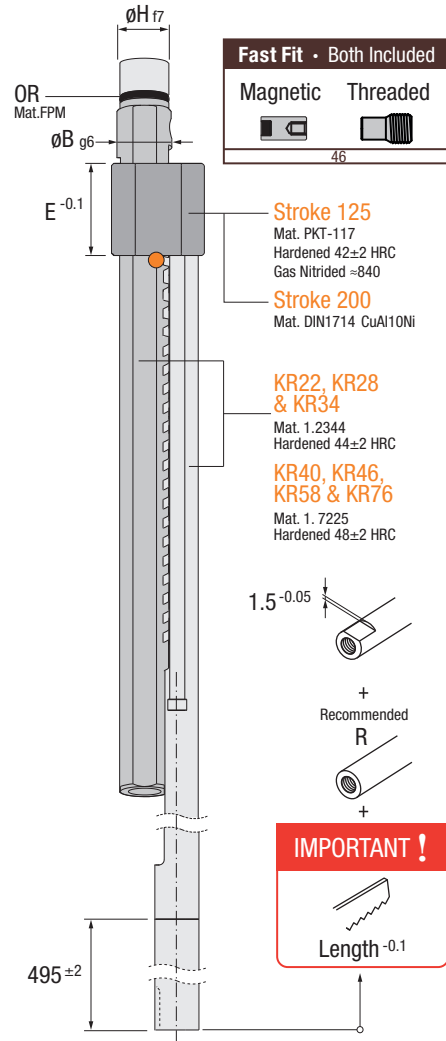
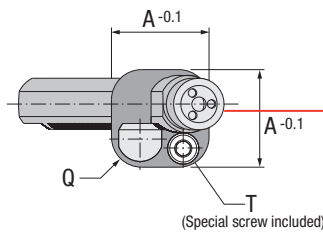

Fast Fit - Both Included

Magnetic Threaded



Stroke 125

Mat. PKT-117
Hardened 42±2 HRC
Gas Nitrided ≈840

Stroke 200

Mat. DIN1714 CuAl10Ni

KR22, KR28
& KR34

Mat. 1.2344
Hardened 44±2 HRC

KR40, KR46,
KR58 & KR76

Mat. 1.7225
Hardened 48±2 HRC

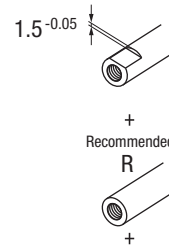

IMPORTANT!

Length -0.1

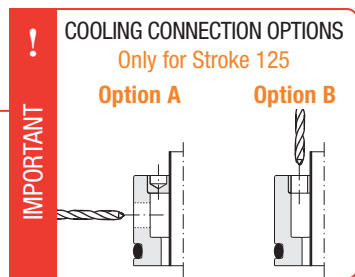

COOLING CONNECTION OPTIONS

Only for Stroke 125

Option A

Option B

IMPORTANT

IMPORTANT

Mirror part.
Pieza simétrica.
Symmetrisches Teil.
Versione a specchio.
Peça em espelho.
Pièce en miroir.

| | Ref. | X° | A | B | C | E | F | G | H | L | P | Q | R | S | T | U | V | OR | Mirror Ref. -S | |
|------------|-------------|---------|----|----|----|----|----|----|------|------|-------|-----|------|-----|---------|-----|----|--------|----------------|---------------|
| Stroke 125 | KR.22125L-x | 8 12 16 | 20 | 22 | 12 | 22 | 16 | 20 | 10.8 | 282 | 260 | 6.5 | M6 | - | M6 | 23 | 8 | 8x1.25 | KR.22125L-x-S | |
| | KR.28125L-x | 8 12 16 | 20 | 28 | 16 | 14 | 28 | 16 | 20 | 13.8 | 294.5 | 272 | 8.5 | M8 | - | M8 | 23 | 8 | 11x1.3 | KR.28125L-x-S |
| | KR.34125L-x | 8 12 16 | 20 | 34 | 20 | 16 | 34 | 18 | 20 | 17.8 | 311.5 | 275 | 10.5 | M8 | - | M8 | 25 | 8 | 14x1.78 | KR.34125L-x-S |
| | KR.40125L-x | 8 12 16 | 20 | 40 | 22 | 20 | 40 | 20 | 25 | 19.8 | 342 | 350 | 10.5 | M10 | - | M10 | 28 | 10 | 15x1.8 | KR.40125L-x-S |
| | KR.46125L-x | 8 12 16 | 20 | 46 | 24 | 24 | 46 | 22 | 25 | 21.8 | 361 | 350 | 10.5 | M12 | - | M12 | 30 | 10 | 18x1.8 | KR.46125L-x-S |
| Stroke 200 | KR.58200L-x | 8 12 16 | - | 58 | 30 | 30 | 66 | 25 | 55 | 26 | 362 | 430 | 13.5 | M20 | 1/4"Gas | M14 | 60 | 12 | 21x2.5 | KR.58200L-x-S |
| | KR.76200L-x | 8 12 16 | - | 76 | 40 | 40 | 80 | 30 | 60 | 34 | 392 | 470 | 17 | M24 | 3/8"Gas | M18 | 70 | 12 | 28x3 | KR.76200L-x-S |

IMPORTANT

Replace the **x** in the reference with the required X° dimension (8°, 12°, 16° or 20°) and indicate the required β°.
 Sustituir la **x** de la referencia por la cota X° deseada (8°, 12°, 16° o 20°), e indique el ángulo β° requerido.
 Ersetzen Sie das **x** der Referenz durch den gewünschten X° Winkel (8°, 12°, 16° oder 20°). Geben Sie den benötigten β° Winkel an.
 Sostituite la **x** del codice con l'angolo X° desiderato (8°, 12°, 16° o 20°) e indicate la β° richiesta.
 Substituir o **x** da referencia pela cota X° desejada (8°, 12°, 16° ou 20°), e indique o angulo β° pretendido.
 Remplacez la valeur **x** par la valeur angulaire X désirée (8, 12, 16 ou 20). Ensuite indiquez l'angle β° correspondant.

INSTALLATION GUIDELINES

ES Consejos de Instalación DE Richtlinien zur Installation
 IT Consigli di Installazione PT Instruções de Instalação FR Mode d'Installation

DR

Core Housing

Alojamiento Placa Punzón
 Einbaumaße DR Führung
 Sede nel Punzone
 Alojamento Bucha
 Logement dans l'empreinte

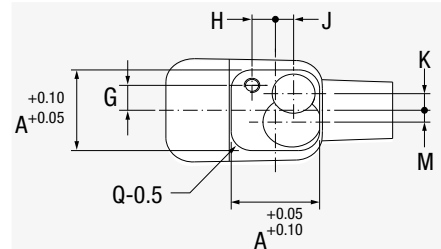
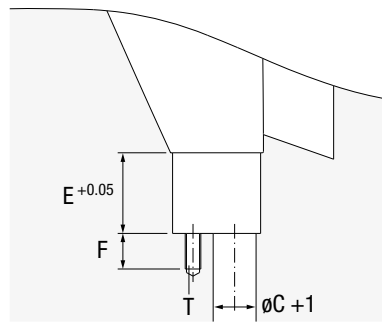
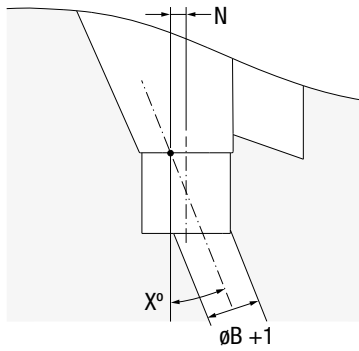

| Stroke 100 | Stroke 125 | Stroke 200 | F | FR1 | FR2 | G | H | J | K | M | N | S | T | W | Y | Z |
|-------------|---------------------------|-------------|----|-----|---------|------|------|-----|------|------|-----|-----|-----|----|------|----|
| DR.16100L.. | - | - | 10 | 4.9 | M8x1 | 4.6 | 4.6 | 3 | 2.35 | 3 | 2.8 | 2.5 | M5 | 6 | 9 | M4 |
| DR.22100L.. | DR.22125L.. / KR.22125L.. | - | 13 | 5.3 | M10x1 | 5.6 | 5.6 | 4.2 | 3.7 | 4.2 | 3.5 | 2.5 | M6 | 8 | 12 | M4 |
| DR.28100L.. | DR.28125L.. / KR.28125L.. | - | 16 | 5.3 | M10x1 | 7.5 | 7.5 | 5 | 5.4 | 4.8 | 4.8 | 2.5 | M8 | 8 | 13.5 | M4 |
| DR.34100L.. | DR.34125L.. / KR.34125L.. | - | 16 | 5.3 | M10x1 | 10.5 | 8 | 7 | 7 | 5 | 6 | 4 | M8 | 8 | 16 | M4 |
| DR.40100L.. | DR.40125L.. | - | 20 | 8.5 | M12x1 | 11 | 11 | 7 | 8 | 7 | 7 | 4 | M10 | 10 | 20 | M6 |
| DR.46100L.. | DR.46125L.. | - | 25 | 8.5 | M12x1 | 13 | 13 | 8 | 8 | 9 | 9 | 5 | M12 | 10 | 24 | M6 |
| - | - | KR.58200L.. | 28 | 8.5 | M16x1.5 | 15.5 | 15.5 | 10 | 12.2 | 11.2 | 10 | 5 | M14 | 12 | 30 | M6 |
| - | - | KR.76200L.. | 36 | 14 | M16x1.5 | 21 | 21 | 13 | 15.2 | 15.2 | 12 | 6 | M18 | 12 | 36 | M6 |

Installation

Instalación · Montage · Montaggio · Instalação · Montage

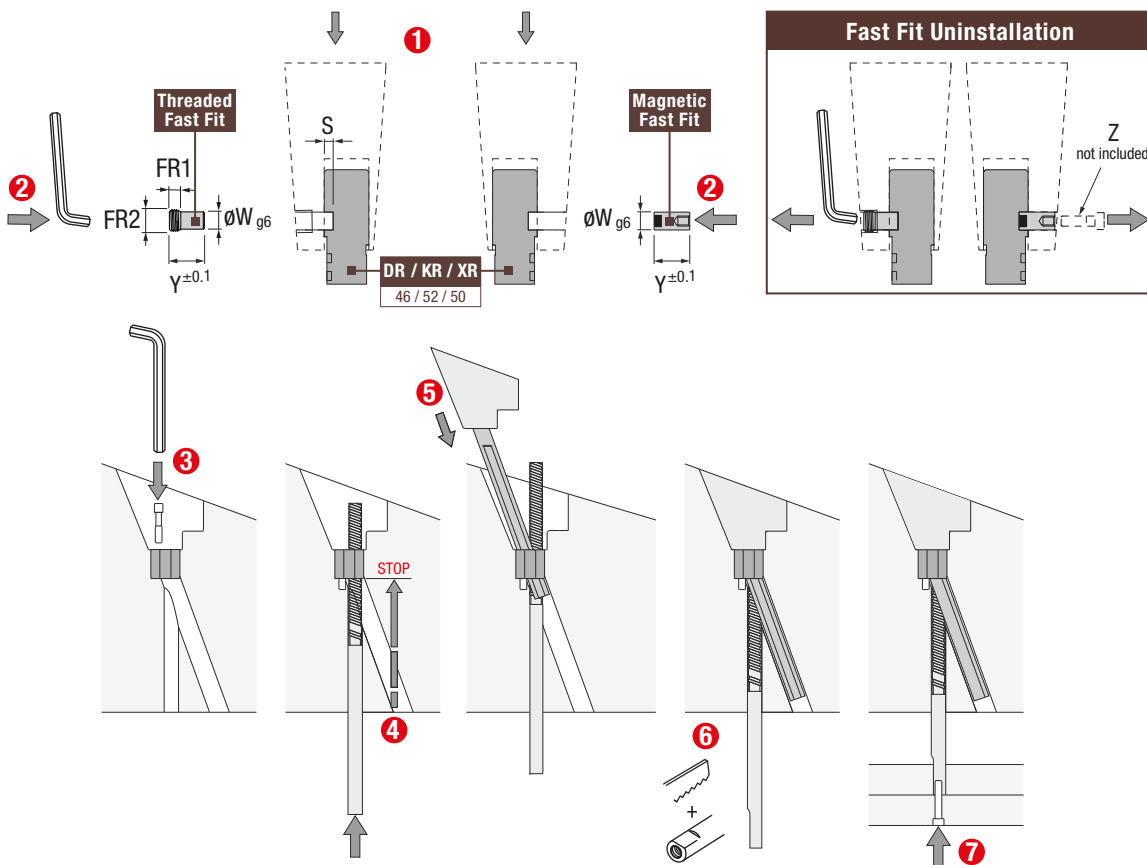

INSTALLATION GUIDELINES

ES Consejos de Instalación DE Richtlinien zur Installation
 IT Consigli di Installazione PT Instruções de Instalação FR Mode d'Installation

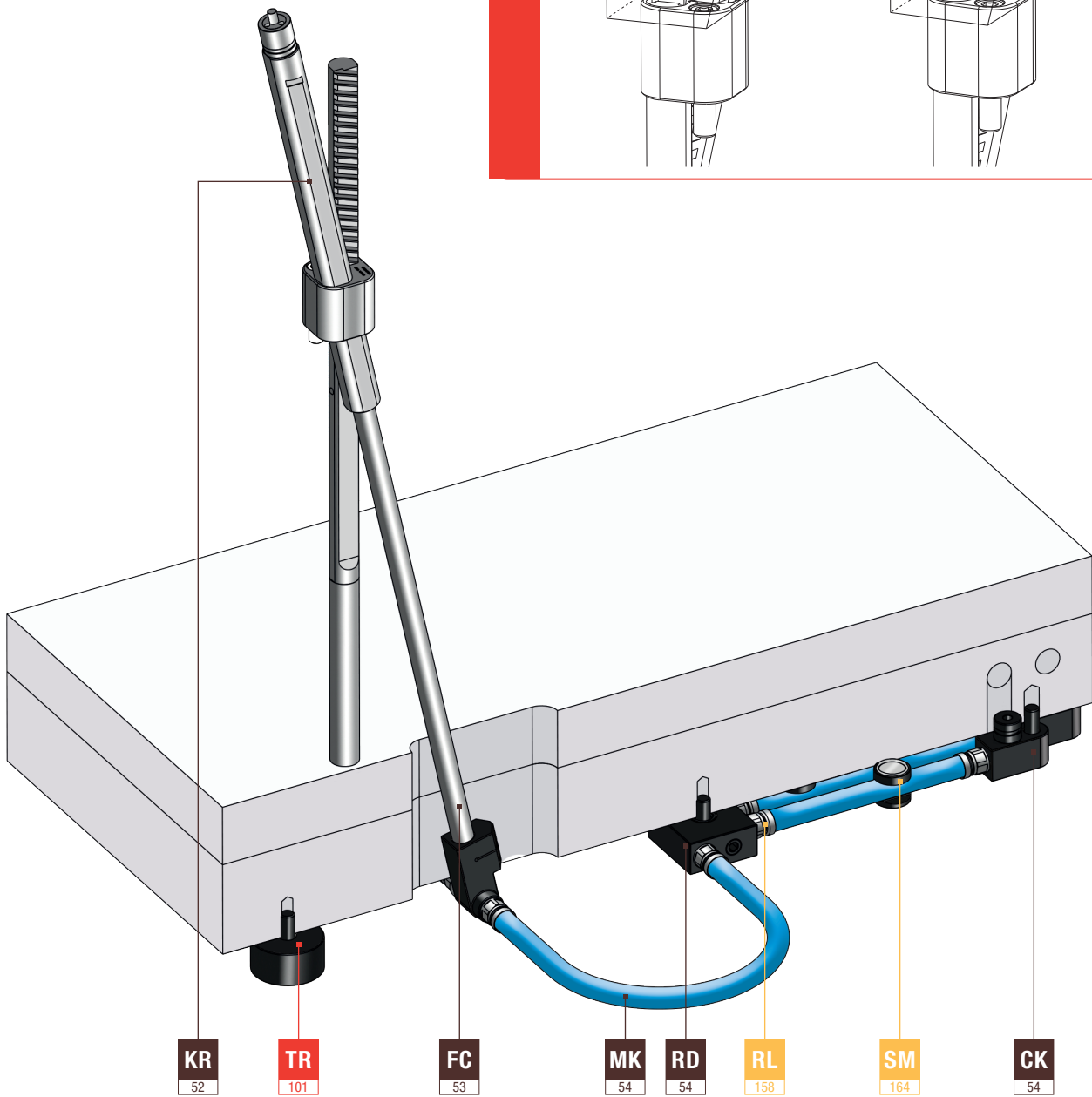
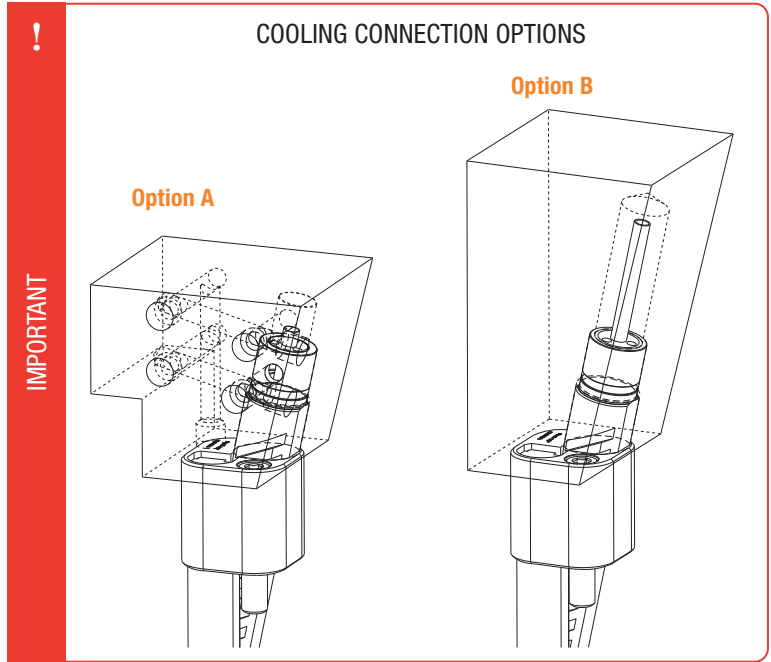

DOUBLE RACK SYSTEM

by CUMSA

COMPARE

Comparativa · Vergleich · Confronto · Comparativo · Comparatif

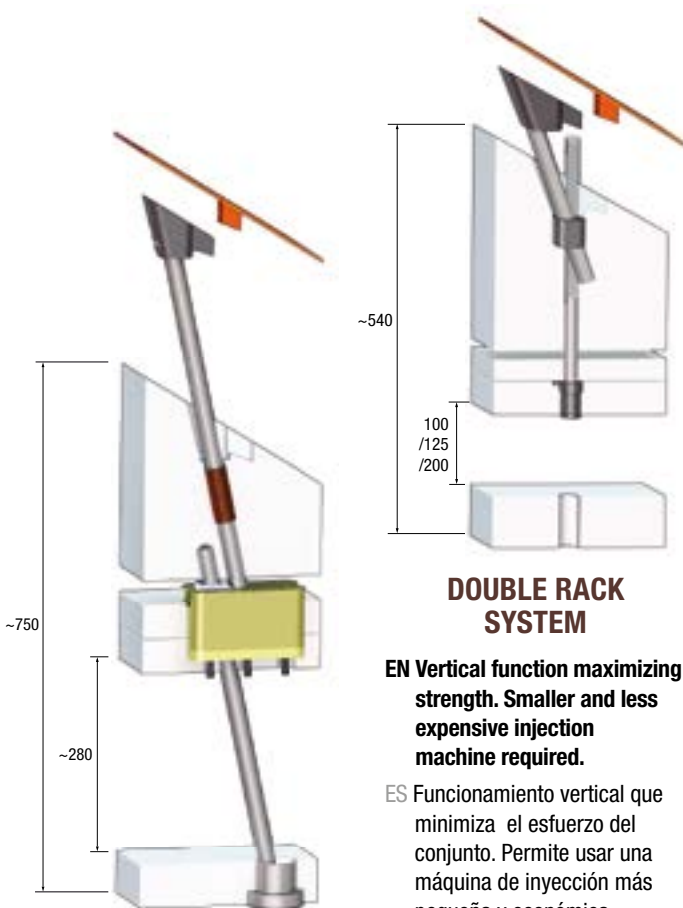

CONVENTIONAL SYSTEM

EN Eliminates the need for high-precision angled housings in the core plates.

ES Elimina los complicados taladros inclinados de alta precisión.

DE Es wird keine hochpräzise Schrägbohrung in der Formplatte benötigt.

IT Elimina le complicate lavorazioni inclinate ad alta precisione.

PT Elimina a necessidade de furos inclinados com precisão.

FR Terminé les logements inclinés de haute précision.

DOUBLE RACK SYSTEM

EN Vertical function maximizing strength. Smaller and less expensive injection machine required.

ES Funcionamiento vertical que minimiza el esfuerzo del conjunto. Permite usar una máquina de inyección más pequeña y económica.

DE Vertikale Funktion mit maximaler Kraft. Ein kleineres Werkzeug kann eventuell eine kleinere und günstigere Spritzgießmaschine benötigen.

IT Funzionamento verticale che minimizza lo sforzo. Permette di usare una macchina d'iniezione più piccola ed economica.

PT Funcionamento na vertical minimizando o esforço. Permite o uso de máquinas de injeção de menores dimensões e mais económicas.

FR Fonctionnement vertical réduisant les efforts. Permet de réduire la dimension de la presse d'injection et ainsi de réaliser des économies.

Neutral angles ($\beta^\circ=0^\circ$)

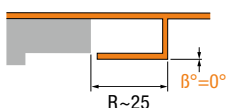

$S \geq R$

DR.xx100L-16
KR.xx200L-16
DR.xx125L-12
KR.xx125L-12
XR.xx100L-24

Positive Angles ($\beta^\circ>0^\circ$)

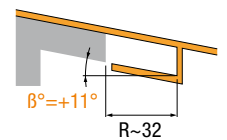

$S \geq R$

DR.xx100L-20
DR.xx125L-16
KR.xx125L-16
XR.xx100L-24

Negative Angles ($\beta^\circ<0^\circ$)

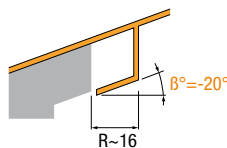

$S \geq R$

DR.xx100L-12
KR.xx200 L-12
DR.xx125L-8
KR.xx125L-8
XR.xx100L-24

IMPORTANT !

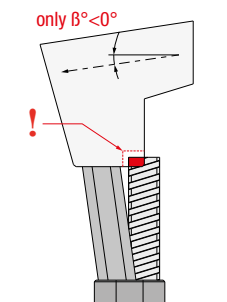

Stroke 100 (DR) Stroke 200 (KR) (Multiply S value x2)

| β° | DR.xx100L-8 | | DR.xx100L-12 | |
|---------------|----------------------|----------------------|----------------------|----------------------|
| | S (- β°) | S (+ β°) | S (- β°) | S (+ β°) |
| 0 | 14.0 | 14.0 | 21.2 | 21.2 |
| 1 | 14.0 | 14.0 | 21.1 | 21.3 |
| 2 | 13.9 | 14.1 | 21.1 | 21.4 |
| 3 | 13.9 | 14.1 | 21.0 | 21.5 |
| 4 | 13.9 | 14.1 | 20.9 | 21.5 |
| 5 | 13.8 | 14.2 | 20.8 | 21.6 |
| 6 | 13.8 | 14.2 | 20.7 | 21.7 |
| 7 | 13.8 | 14.3 | 20.7 | 21.8 |
| 8 | 13.7 | 14.3 | 20.6 | 21.9 |
| 9 | 13.7 | 14.3 | 20.5 | 22.0 |
| 10 | 13.7 | 14.4 | 20.4 | 22.0 |
| 11 | 13.6 | 14.4 | 20.4 | 22.1 |
| 12 | 13.6 | 14.4 | 20.3 | 22.2 |
| 13 | 13.6 | 14.5 | 20.2 | 22.3 |
| 14 | 13.5 | 14.5 | 20.1 | 22.4 |
| 15 | 13.5 | 14.6 | 20.1 | 22.5 |
| 16 | 13.5 | 14.6 | 20.0 | 22.6 |
| 17 | 13.4 | 14.6 | 19.9 | 22.7 |
| 18 | 13.4 | 14.7 | 19.8 | 22.8 |
| 19 | 13.4 | 14.7 | 19.8 | 22.9 |
| 20 | 13.3 | 14.8 | 19.7 | 23.0 |
| 21 | 13.3 | 14.8 | 19.6 | 23.1 |
| 22 | 13.2 | 14.9 | 19.5 | 23.2 |
| 23 | 13.2 | 14.9 | 19.4 | 23.3 |
| 24 | 13.2 | 14.9 | 19.4 | 23.4 |
| 25 | 13.1 | 15.0 | 19.3 | 23.5 |
| 26 | 13.1 | 15.0 | 19.2 | 23.7 |
| 27 | 13.1 | 15.1 | 19.1 | 23.8 |
| 28 | 13.0 | 15.1 | 19.0 | 23.9 |
| 29 | 13.0 | 15.2 | 19.0 | 24.0 |
| 30 | 12.9 | 15.2 | 18.9 | 24.2 |
| 31 | 12.9 | 15.3 | 18.8 | |
| 32 | 12.9 | 15.4 | 18.7 | |
| 33 | 12.8 | 15.4 | 18.6 | |
| 34 | 12.8 | 15.5 | 18.5 | |
| 35 | 12.7 | 15.5 | 18.5 | |
| 36 | 12.7 | | 18.4 | |
| 37 | 12.7 | | 18.3 | |
| 38 | 12.6 | | 18.2 | |
| 39 | 12.6 | | 18.1 | |
| 40 | 12.5 | | 18.0 | |
| 45 | 12.3 | | 17.5 | |
| 50 | 12.0 | | 16.9 | |
| 55 | 11.7 | | 16.3 | |
| 60 | 11.3 | | 15.5 | |

SELECTION TABLE: WHICH DR / KR DO I NEED?

ES TABLA DE SELECCIÓN: Qué DR / KR / XR necesito?

DE AUSWAHLTABELLE: Welcher DR / KR / XR ist am besten geeignet?

IT TABELLA PER SCELTA: Di quale DR / KR / XR ho bisogno?

PT TABELA DE SELEÇÃO: Qual é o DR / KR / XR que preciso?

FR TABLEAU DE CORRESPONDANCE: Quel est le DR / KR que j'ai besoin?



Stroke 100 (DR) Stroke 200 (KR) (Multiply S value x2)

| | DR.xx100L-16 | | DR.xx100L-20 | |
|------|--------------|---------|--------------|---------|
| | S (-β°) | S (+β°) | S (-β°) | S (+β°) |
| | 28.6 | | 36.4 | |
| 28.5 | 28.8 | 36.1 | 36.6 | |
| 28.3 | 28.9 | 35.9 | 36.8 | |
| 28.2 | 29.1 | 35.7 | 37.1 | |
| 28.1 | 29.2 | 35.4 | 37.3 | |
| 27.9 | 29.4 | 35.2 | 37.5 | |
| 27.8 | 29.5 | 35.0 | 37.8 | |
| 27.7 | 29.7 | 34.8 | 38.1 | |
| 27.5 | 29.8 | 34.6 | 38.3 | |
| 27.4 | 30.0 | 34.4 | 38.6 | |
| 27.2 | 30.2 | 34.2 | 38.8 | |
| 27.1 | 30.3 | 33.9 | 39.1 | |
| 27.0 | 30.5 | 33.7 | 39.4 | |
| 26.8 | 30.7 | 33.5 | 39.7 | |
| 26.7 | 30.8 | 33.3 | 40.0 | |
| 26.6 | 31.0 | 33.1 | 40.3 | |
| 26.5 | 31.2 | 32.9 | 40.6 | |
| 26.3 | 31.4 | 32.7 | 40.9 | |
| 26.2 | 31.6 | 32.5 | 41.2 | |
| 26.1 | 31.8 | 32.3 | 41.6 | |
| 25.9 | 32.0 | 32.1 | 41.9 | |
| 25.8 | 32.2 | 31.9 | | |
| 25.6 | 32.4 | 31.7 | | |
| 25.5 | 32.6 | 31.5 | | |
| 25.4 | 32.8 | 31.3 | | |
| 25.2 | 33.1 | 31.1 | | |
| 25.1 | | 30.9 | | |
| 25.0 | | 30.7 | | |
| 24.8 | | 30.4 | | |
| 24.7 | | 30.2 | | |
| 24.6 | | 30.0 | | |
| 24.4 | | 29.8 | | |
| 24.3 | | 29.6 | | |
| 24.1 | | 29.4 | | |
| 24.0 | | 29.2 | | |
| 23.8 | | 29.0 | | |
| 23.7 | | 28.7 | | |
| 23.5 | | 28.5 | | |
| 23.4 | | 28.3 | | |
| 23.2 | | 28.1 | | |
| 23.1 | | 27.8 | | |
| 22.2 | | 26.6 | | |
| 21.3 | | 25.1 | | |
| 20.3 | | 23.9 | | |
| 19.1 | | 22.3 | | |

Stroke 125 (DR / KR)

| β° | DR.xx125L-8 | | DR.xx125L-12 | | DR.xx125L-16 | | DR.xx125L-20 | |
|----|-------------|---------|--------------|---------|--------------|---------|--------------|---------|
| | KR.xx125L-8 | | KR.xx125L-12 | | KR.xx125L-16 | | KR.xx125L-20 | |
| | S (-β°) | S (+β°) | S (-β°) | S (+β°) | S (-β°) | S (+β°) | S (-β°) | S (+β°) |
| 0 | 17.5 | | 26.5 | | 35.8 | | 45.4 | |
| 1 | 17.5 | 17.6 | 26.4 | 26.6 | 35.6 | 36.0 | 45.2 | 45.7 |
| 2 | 17.4 | 17.6 | 26.3 | 26.7 | 35.4 | 36.2 | 44.9 | 46.0 |
| 3 | 17.4 | 17.6 | 26.2 | 26.8 | 35.3 | 36.3 | 44.6 | 46.3 |
| 4 | 17.3 | 17.7 | 26.1 | 26.9 | 35.1 | 36.5 | 44.3 | 46.6 |
| 5 | 17.3 | 17.7 | 26.0 | 27.0 | 34.9 | 36.7 | 44.0 | 46.9 |
| 6 | 17.3 | 17.8 | 25.9 | 27.1 | 34.7 | 36.9 | 43.8 | 47.3 |
| 7 | 17.2 | 17.8 | 25.8 | 27.2 | 34.6 | 37.1 | 43.5 | 47.6 |
| 8 | 17.2 | 17.9 | 25.7 | 27.3 | 34.4 | 37.3 | 43.2 | 47.9 |
| 9 | 17.1 | 17.9 | 25.7 | 27.4 | 34.2 | 37.5 | 43.0 | 48.2 |
| 10 | 17.1 | 18.0 | 25.6 | 27.6 | 34.1 | 37.7 | 42.7 | 48.6 |
| 11 | 17.1 | 18.0 | 25.5 | 27.7 | 33.9 | 37.9 | 42.4 | 48.9 |
| 12 | 17.0 | 18.1 | 25.4 | 27.8 | 33.7 | 38.1 | 42.2 | 49.3 |
| 13 | 17.0 | 18.1 | 25.3 | 27.9 | 33.6 | 38.3 | 41.9 | 49.6 |
| 14 | 16.9 | 18.2 | 25.2 | 28.0 | 33.4 | 38.6 | 41.7 | 50.0 |
| 15 | 16.9 | 18.2 | 25.1 | 28.1 | 33.2 | 38.8 | 41.4 | 50.4 |
| 16 | 16.8 | 18.3 | 25.0 | 28.2 | 33.1 | 39.0 | 41.1 | 50.7 |
| 17 | 16.8 | 18.3 | 24.9 | 28.4 | 32.9 | 39.2 | 40.9 | 51.1 |
| 18 | 16.8 | 18.4 | 24.8 | 28.5 | 32.7 | 39.5 | 40.6 | 51.5 |
| 19 | 16.7 | 18.4 | 24.7 | 28.6 | 32.6 | 39.7 | 40.4 | 52.0 |
| 20 | 16.7 | 18.5 | 24.6 | 28.7 | 32.4 | 40.0 | 40.1 | 52.4 |
| 21 | 16.6 | 18.5 | 24.5 | 28.9 | 32.2 | 40.2 | 39.9 | |
| 22 | 16.6 | 18.6 | 24.4 | 29.0 | 32.1 | 40.5 | 39.6 | |
| 23 | 16.5 | 18.6 | 24.3 | 29.2 | 31.9 | 40.8 | 39.4 | |
| 24 | 16.5 | 18.7 | 24.2 | 29.3 | 31.7 | 41.0 | 39.1 | |
| 25 | 16.4 | 18.7 | 24.1 | 29.4 | 31.6 | 41.3 | 38.8 | |
| 26 | 16.4 | 18.8 | 24.0 | 29.6 | 31.4 | | 38.6 | |
| 27 | 16.3 | 18.9 | 23.9 | 29.7 | 31.2 | | 38.3 | |
| 28 | 16.3 | 18.9 | 23.8 | 29.9 | 31.1 | | 38.1 | |
| 29 | 16.2 | 19.0 | 23.7 | 30.1 | 30.9 | | 37.8 | |
| 30 | 16.2 | 19.1 | 23.6 | 30.2 | 30.7 | | 37.5 | |
| 31 | 16.1 | 19.1 | 23.5 | | 30.5 | | 37.3 | |
| 32 | 16.1 | 19.2 | 23.4 | | 30.3 | | 37.0 | |
| 33 | 16.0 | 19.3 | 23.3 | | 30.2 | | 36.7 | |
| 34 | 16.0 | 19.4 | 23.2 | | 30.0 | | 36.5 | |
| 35 | 15.9 | 19.4 | 23.1 | | 29.8 | | 36.2 | |
| 36 | 15.9 | | 23.0 | | 29.6 | | 35.9 | |
| 37 | 15.8 | | 22.9 | | 29.4 | | 35.7 | |
| 38 | 15.8 | | 22.7 | | 29.2 | | 35.4 | |
| 39 | 15.7 | | 22.6 | | 29.0 | | 35.1 | |
| 40 | 15.7 | | 22.5 | | 28.8 | | 34.8 | |
| 45 | 15.4 | | 21.9 | | 27.8 | | 33.3 | |
| 50 | 15.0 | | 21.1 | | 26.7 | | 31.7 | |
| 55 | 14.6 | | 20.3 | | 25.4 | | 29.9 | |
| 60 | 14.1 | | 19.4 | | 23.9 | | 27.9 | |

Stroke 100 (XR)

| β° | XRxx100L-24 | | XRxx100L-28 | | XRxx100L-32 | | XRxx100L-36 | |
|----|-------------|---------|-------------|---------|-------------|---------|-------------|---------|
| | S (-β°) | S (+β°) | S (-β°) | S (+β°) | S (-β°) | S (+β°) | S (-β°) | S (+β°) |
| 0 | 44.5 | | 53.2 | | 62.5 | | 72.7 | |
| 1 | 44.2 | 44.9 | 52.7 | 53.7 | 61.8 | 63.2 | 71.7 | 73.6 |
| 2 | 43.8 | 45.2 | 52.2 | 54.2 | 61.2 | 63.9 | 70.9 | 74.5 |
| 3 | 43.5 | 45.6 | 51.7 | 54.7 | 60.5 | 64.6 | 70.0 | 75.5 |
| 4 | 43.2 | 46.0 | 51.3 | 55.2 | 59.9 | 65.3 | 69.1 | 76.5 |
| 5 | 42.9 | 46.3 | 50.8 | 55.8 | 59.2 | 66.1 | 68.3 | 77.6 |
| 6 | 42.5 | 46.7 | 50.4 | 56.3 | 58.6 | 66.9 | 67.5 | 78.7 |
| 7 | 42.2 | 47.1 | 49.9 | 56.9 | 58.0 | 67.7 | 66.7 | 79.8 |
| 8 | 41.9 | 47.5 | 49.5 | 57.5 | 57.4 | 68.5 | 65.9 | |
| 9 | 41.6 | 47.9 | 49.0 | 58.1 | 56.9 | 69.4 | 65.2 | |
| 10 | 41.3 | 48.3 | 48.6 | 58.7 | 56.3 | 70.2 | 64.4 | |
| 11 | 41.0 | 48.7 | 48.2 | 59.3 | 55.7 | 71.1 | 63.7 | |
| 12 | 40.7 | 49.2 | 47.8 | 59.9 | 55.2 | | 62.9 | |
| 13 | 40.4 | 49.6 | 47.4 | 60.6 | 54.6 | | 62.2 | |
| 14 | 40.1 | 50.1 | 46.9 | 61.3 | 54.1 | | 61.5 | |
| 15 | 39.8 | 50.6 | 46.5 | 62.0 | 53.5 | | 60.8 | |
| 16 | 39.5 | 51.0 | 46.1 | | 53.0 | | 60.1 | |
| 17 | 39.2 | 51.5 | 45.7 | | 52.5 | | 59.4 | |
| 18 | 38.9 | 52.1 | 45.3 | | 51.9 | | 58.8 | |
| 19 | 38.6 | 52.6 | 44.9 | | 51.4 | | 58.1 | |
| 20 | 38.3 | | 44.5 | | 50.9 | | 57.5 | |
| 21 | 38.0 | | 44.2 | | 50.4 | | 56.8 | |
| 22 | 37.7 | | 43.8 | | 49.9 | | 56.2 | |
| 23 | 37.4 | | 43.4 | | 49.4 | | 55.5 | |
| 24 | 37.2 | | 43.0 | | 48.9 | | 54.9 | |
| 25 | 36.9 | | 42.6 | | 48.4 | | 54.3 | |
| 26 | 36.6 | | 42.2 | | 47.9 | | 53.6 | |
| 27 | 36.3 | | 41.8 | | 47.4 | | 53.0 | |
| 28 | 36.0 | | 41.5 | | 46.9 | | 52.4 | |
| 29 | 35.7 | | 41.1 | | 46.4 | | 51.8 | |
| 30 | 35.4 | | 40.7 | | 45.9 | | 51.2 | |
| 31 | 35.1 | | 40.3 | | 45.4 | | 50.6 | |
| 32 | 34.8 | | 39.9 | | 44.9 | | 50.0 | |
| 33 | 34.5 | | 39.5 | | 44.4 | | 49.4 | |
| 34 | 34.2 | | 39.1 | | 44.0 | | 48.8 | |
| 35 | 33.9 | | 38.7 | | 43.5 | | 48.2 | |
| 36 | 33.6 | | 38.4 | | 43.0 | | 47.6 | |
| 37 | 33.3 | | 38.0 | | 42.5 | | 46.9 | |
| 38 | 33.0 | | 37.6 | | 42.0 | | 46.3 | |
| 39 | 32.7 | | 37.2 | | 41.5 | | 45.7 | |
| 40 | 32.4 | | 36.8 | | 41.0 | | 45.1 | |
| 45 | 30.8 | | 34.7 | | 38.4 | | 42.0 | |
| 50 | | | | | | | | |
| 55 | | | | | | | | |
| 60 | | | | | | | | |

Special β° angles possible under request
ES Posibilidad de ángulos β° especiales DE Sonderwinkel auf Anfrage möglich (β°) IT E' possibile avere angolazioni β° speciali su richiesta PT Possibilidade de ângulos β° especiais FR Possibilité de réaliser des angles β° spéciaux.