

BRB4

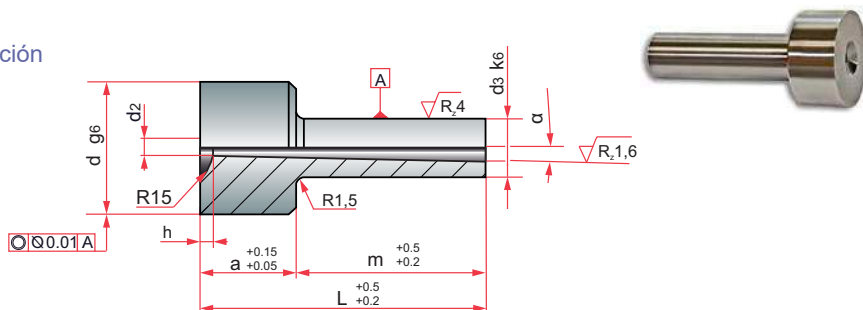

Sprue brushing
 Bebedero de inyección
 Tuleja wtryskowa
 Injector
 Buse d'injection



Mat. : 1.1191. Hardness: 21-23 HRC.

| d ₂ | h | α (°) | d | m | a | d ₃ | L | REF. |
|----------------|---|-------|----|-------|----|----------------|-------|------------|
| 5 | 3 | 1 | 50 | 76,5 | 26 | 25 | 102,5 | BRB4-102,5 |
| | | | | 86,5 | | | 112,5 | BRB4-112,5 |
| | | | | 96,5 | | | 122,5 | BRB4-122,5 |
| | | | | 106,5 | | | 132,5 | BRB4-132,5 |
| | | | | 116,5 | | | 142,5 | BRB4-142,5 |
| | | | | 126,5 | | | 152,5 | BRB4-152,5 |
| | | | | 136,5 | | | 162,5 | BRB4-162,5 |
| | | | | 156,5 | | | 182,5 | BRB4-182,5 |

BRB7

Sprue brushing
 Bebedero de inyección
 Tuleja wtryskowa
 Injector
 Buse d'injection

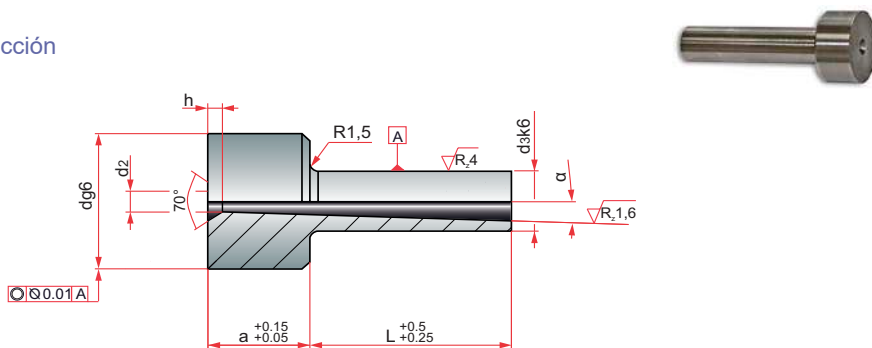

Mat. : 1.1191. Hardness: 21-23 HRC.

| d ₂ | h | α (°) | d | a | d ₃ | L | REF. |
|----------------|---|-------|----|----|----------------|-----|----------|
| 4 | 3 | 1 | 35 | 18 | 18 | 27 | BRB7-027 |
| | | | | | | 36 | BRB7-036 |
| | | | | | | 46 | BRB7-046 |
| | | | | | | 56 | BRB7-056 |
| | | | | | | 76 | BRB7-076 |
| | | | | | | 96 | BRB7-096 |
| | | | | | | 116 | BRB7-116 |